

TYPE 1

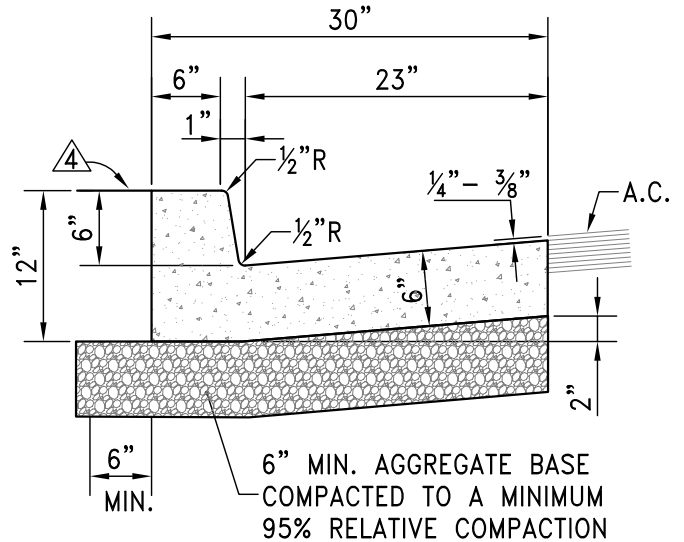

TYPE 1A

NOTES:

1. FIBER-REINFORCED PORTLAND CEMENT CONCRETE (P.C.C.) SHALL HAVE THE FOLLOWING CHARACTERISTICS: 4000 PSI MIN. COMPRESSIVE STRENGTH AT 28 DAYS, MIN. 6 SACKS OF CEMENT PER CUBIC YARD WITH MAX. WATER-CEMENT RATIO OF 0.45, AIR ENTRAINMENT 6% ±1.5%, SLUMP AT 1 TO 4 INCHES. MIX DESIGN SHALL CONFORM TO THE REQUIREMENTS OF SECTION 337 OF STANDARD SPECIFICATIONS OF PUBLIC WORKS CONSTRUCTION (SSPWC). CEMENT SHALL BE TYPE II. ALL CEMENT CONCRETE SHALL HAVE A COARSE AGGREGATE GRADATION CONFORMING TO SIZE No. 67. POLYPROPYLENE OR CELLULOSE FIBERS SHALL BE ADDED TO THE P.C.C. AT 1.5 LBS. PER CUBIC YARD. ALL MATERIALS SHALL CONFORM TO SSPWC.
2. AGGREGATE BASE MATERIAL UNDER AND BEHIND CURB AND GUTTER SHALL BE TYPE 2, CLASS B CRUSHED AGGREGATE BASE. MATERIALS SHALL CONFORM TO SSPWC SECTION 200.
3. WEAKENED PLANE JOINTS SHALL BE EVERY 10 FEET AND LOCATED ON THE BACK, TOP AND FACE OF THE CURB AND THE TOP OF THE GUTTER PAN.
4. CURB & GUTTER SECTIONS SHALL BE PLACED SEPARATELY FROM SIDEWALK SECTIONS. WHEN SIDEWALK IS NOT REQUIRED DIRECTLY BEHIND THE CURB, BACKFILL TO TOP OF CURB FOR A HORIZONTAL DISTANCE OF 12" FROM BACK FACE OF CURB AND COMPACT TO 90% RELATIVE COMPACTION.
5. FOR REPLACEMENT OF EXISTING CURB AND GUTTER, MATCH EXISTING TYPE.



STANDARD DETAILS FOR PUBLIC WORKS CONSTRUCTION

DRAWING No.

**P.C.C.
CURB & GUTTER**

R-109

APPROVED BY: JF | DATE: 1/2013